



Adoption and Integration Program Use Case Documentation

1. Use case name

Note that an organization that is creating records, integrating into a repository, and integrating into a researcher information system would have three use case reports.

Society for Neuroscience ORCID Integration Into Membership Database

2. Institution name

Society for Neuroscience

3. Project goals and scope

Please provide an overview of your project, why your organization chose to undertake it, what you hoped to achieve, and the scope of the project.

As a large scientific organization with a sophisticated data management strategy and operations, the Society for Neuroscience (SfN) recognizes the importance and challenge of distinguishing among researchers and maintaining data integrity across systems and disciplines. ORCID's mission to solve name ambiguity via a central registry is an important step toward promoting accuracy and integrity in scholarly research, an endeavor central to SfN's commitment to supporting neuroscience research and creating venues for great science.

SfN plans to integrate the ORCID registration process with the related account registration processes that currently occur in the Association Management System (AMS). Wherever possible, SfN aims to filter transactional member and nonmember interactions through the AMS, Personify. Personify is a modular, enterprise system that supports the full range of business and administrative activities required by the association. It is a best-of-breed system that accommodates integrations through its "open" framework, through Application Programming Interface (API) technology. The main integration points where ORCID will be implemented in Personify are:

- 1) Account Registration – site visitor wishes to create an account with SfN (to purchase a product, sign up for alerts, etc)
- 2) New Member and Returning Member Workflows – an individual seeks to join or re-join SfN
- 3) My Profile / My SfN – an individual logs into the My SfN Section to leverage personalized content

As a result of the ORCID integration, SfN envisions a space where members can:

- 1) Accurately distinguish themselves and their activities from other researchers, minimizing misidentification
- 2) Centrally maintain their research activities with SfN and ORCID, two organizations positioned to reach across disciplines and national boundaries (approximately 38% of SfN's members reside outside of the United States)
- 3) Benefit from efficiencies where common information is not re-entered across systems

4. Is your organization willing to serve as a resource for other organizations pursuing ORCID integration?

Yes

5. Project personnel

Please include name, title, phone number, and email address for each contact:

- a. Project leader
 - i. Nick Fletcher, Project Manager, (202) 962-4070, nfletcher@sfn.org
- b. Technical contact
 - i. Tsega Gari, Application Development Manager, (202) 962-4071, tgari@sfn.org
- c. Other team members
 - i. Jenna Welch, Membership & Chapters Manager, (202) 962-4015, jwelch@sfn.org
 - ii. Scott Moore, Director of Technology Services, (202) 962-4069, scott@sfn.org
 - iii. Melanie Willis, Information Systems Manager, (202) 962-4099, mwillis@sfn.org

6. System(s) involved. Provide a workflow diagram showing where ORCID identifiers were collected and the system(s) modified to collect and/or store ORCID identifiers.
A sample workflow diagram is available at <https://ORCID.org/blog/2013/08/08/suggested-practices-collection-and-display-ORCID-ids-publishing-workflows?lang=zh-hant>.

User View Workflows are below. Detailed diagrams illustrating Personify and ORCID’s integration can be found in Appendix A.

Integration Point 1: Account Registration Workflow

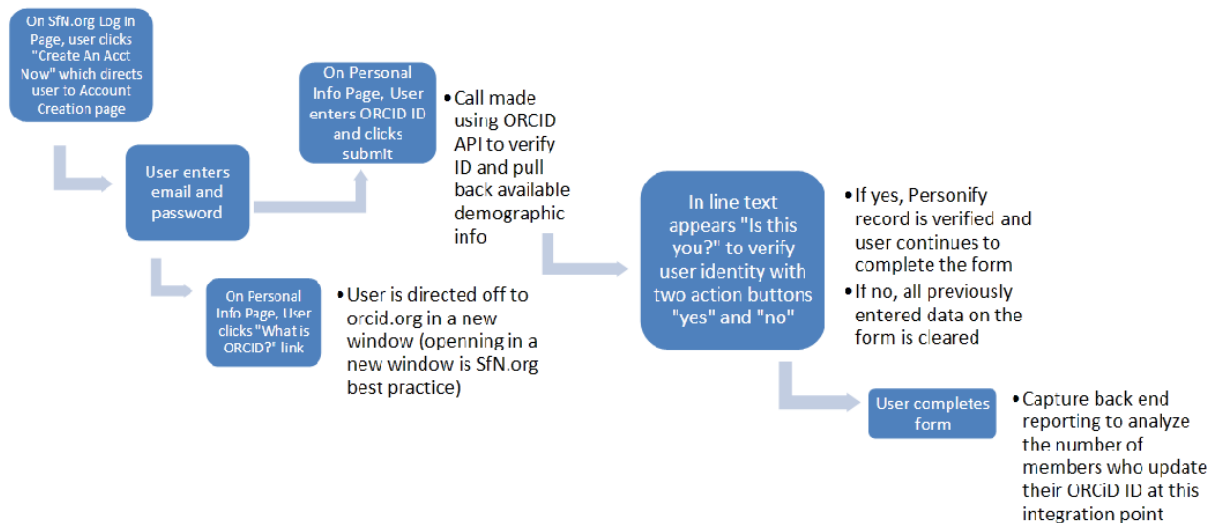

Integration Point 2: Membership Workflow

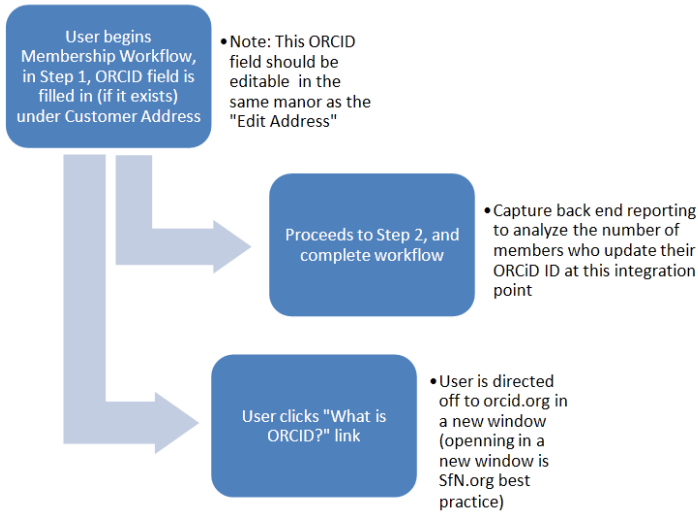

Integration Point 3: My SfN

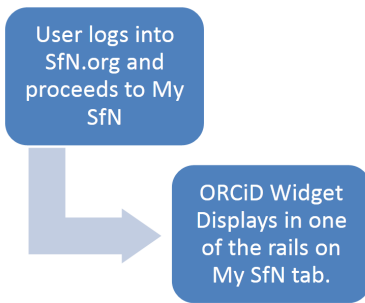

7. Project timeline

Please provide a brief overview of when your project began and its timeline for completion.

Activity	Start Date	Projected End Date
Kickoff	12/3/2013	12/3/2013
Discovery	12/11/2013	12/30/2013
Finalize ORCID Membership Agreement	1/1/2014	1/1/2014
ORCID Sandbox Set Up	1/3/2014	1/10/2014
Development/Test - Phase I	2/14/2014	3/11/2014
ORCID onsite visit	3/13/2014	3/13/2014
Development/Test - Phase II	3/14/2014	5/8/2014
Use Case Due	3/28/2014	3/28/2014
Demo of Prototype (in Chicago)	5/21/2014	5/22/2014
Development/Test III	5/22/2014	8/21/2014
Go Live	8/30/2014	8/30/2014

Post Code to GitHub	9/15/2014	9/15/2014
Project Summary Slides for Open Dissemination	9/15/2014	9/15/2014
Financial Review	9/30/2014	9/30/2014

8. Project web page(s)

Society Homepage: www.sfn.org

Production ORCID/Personify Integration Point 1: Account Registration – <http://www.sfn.org/my-sfn/account-registration>

Production ORCID/Personify Integration Point 2: New Member, Returning Member Workflow – <http://www.sfn.org/Member-Center/Join-or-Renew/Membership-Login>

Production ORCID/Personify Integration Point 3: My SfN / My Profile - <http://www.sfn.org/my-sfn/my-sfn>

Sandbox ORCID/Personify Integration Point 1: Account Registration - <http://sandbox.sfn.org/my-sfn/account-registration>

Sandbox ORCID/Personify Integration Point 2: New Member, Returning Member Workflow - <http://sandbox.sfn.org/my-sfn/my-sfn>

Sandbox ORCID/Personify Integration Point 3: My SfN / My Profile - <http://sandbox.sfn.org/member-center/join-or-renew/membership-login>

*Note: Please do not use Sandbox links for marketing purposes.

9. Please identify the stakeholder groups within this project and describe the outreach/communications work your organization arranged in advance of implementation. Which stakeholders did you contact? How did you organize a team? What were the policy impacts?

Beyond SfN and ORCID, the project stakeholders are individual researchers with a relationship to SfN.

Internally, several SfN departments came together to form the ORCID Integration Project Team. SfN's project team consists of team members from Membership, Technical Support and Project Management departments. The team works closely with the Grants department for financial auditing purposes as well as the Journal department who is also integrating ORCID into the Society's Journal submission process in parallel with the A&I integration.

No outreach was performed in advance of the implementation.

10. Please provide an overview of your communications plan as well as examples of your communications outputs, which may be adapted by other organizations for their integrations.

This includes email messages, web pages, LibGuides, press releases, instructional videos, internal documentation, training materials, etc.



Adoption and Integration Program Use Case Documentation

When fully integrated, SfN plans to utilize social media tools such as Facebook and Twitter to publicize ORCID. SfN also plans to utilize other marketing channels such as newsletters and web news articles and will incorporate language into renewal notice and member data maintenance notices.

SfN encourages ORCID to consider exhibiting at Neuroscience 2014 in Washington, DC. SfN's annual meeting is a great way for ORCID to promote its value to over 30,000 researchers in one central location.

11. Are you willing to share your source code? If yes, please provide a link.

Yes, the URL will be provided closer to launch

Samples are available at <https://github.com/CrossRef/cr-search> and <https://github.com/TomDemeranville/ORCID-update-java>.

DRAFT

Appendix A - Use Case and Sequence Diagrams

Use case diagram

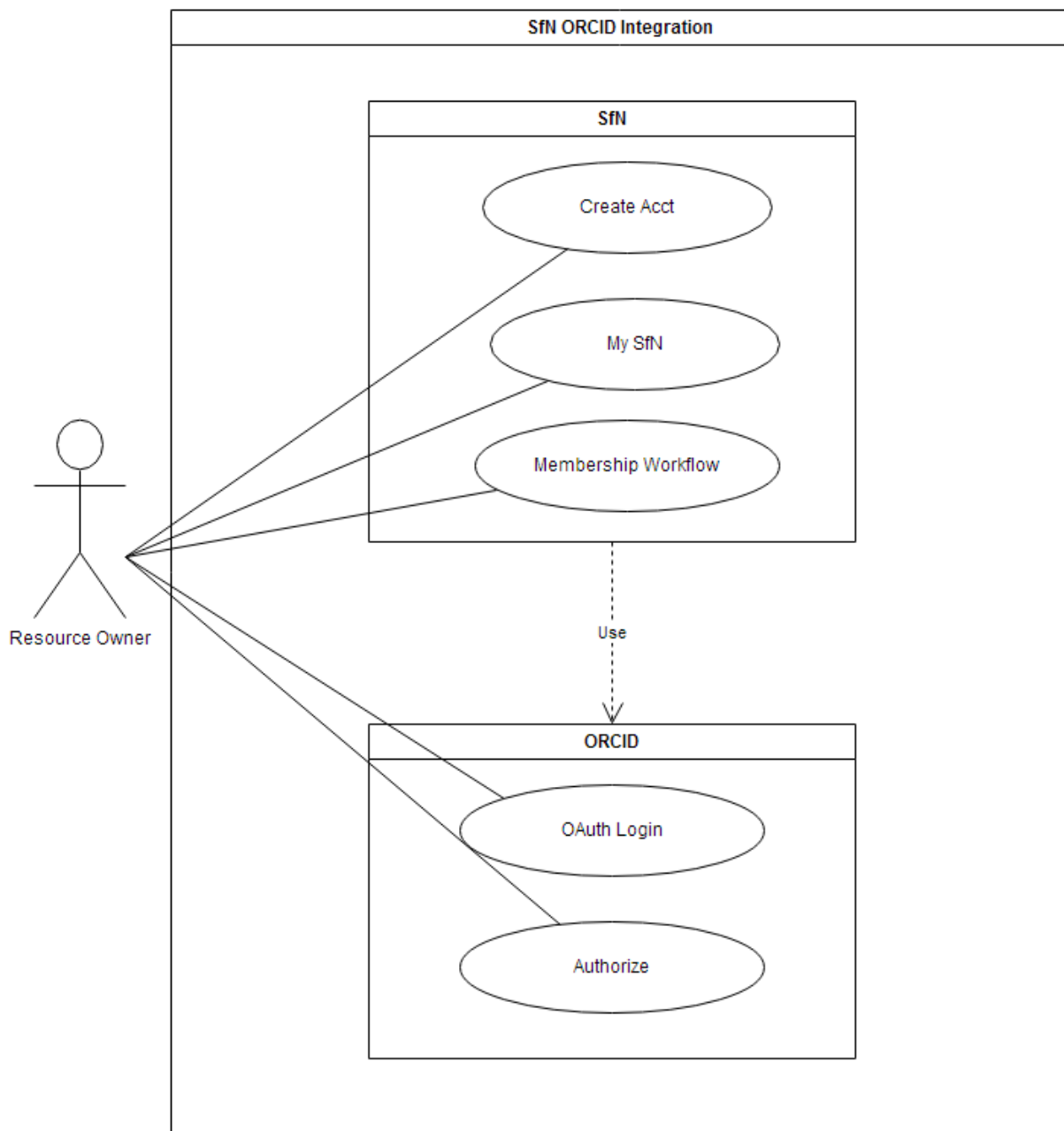

Create Account Sequence diagram

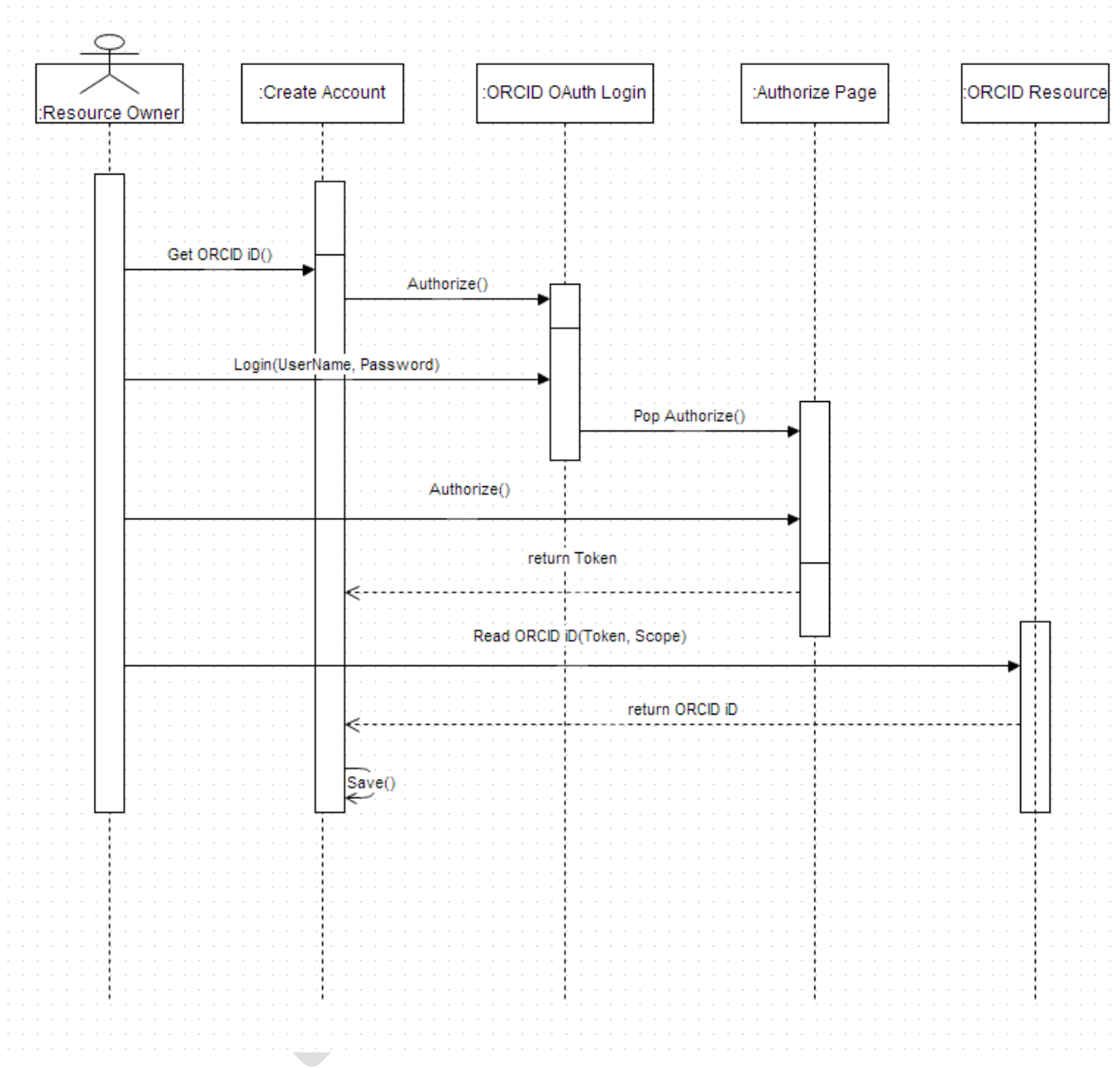

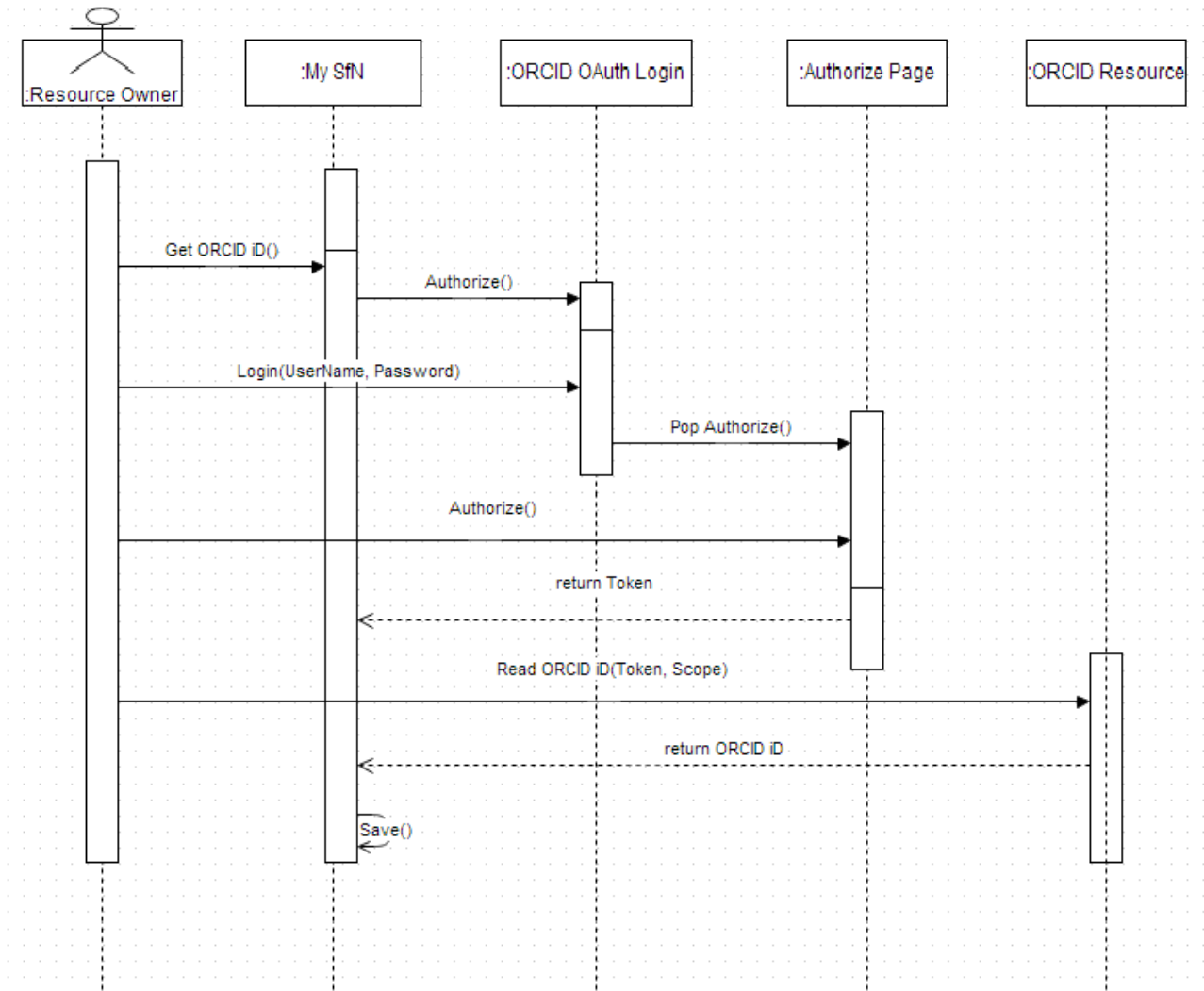

Member Status Sequence diagram

